



Limitations of Traditional PV Systems

Traditional residential and commercial photovoltaic installations suffer from a broad range of limitations that prevent them from reaching their full potential and achieving broader market acceptance. These limitations fall into a number of categories. For a more complete analysis of these limitations, please read the SolarEdge paper “Problems and Disadvantages in Current Residential and Commercial On-Grid PV Systems.”

- **Power Losses** - Traditional systems produce anywhere from 5% to 25% less than optimal power because of conditions like module mismatch, partial shading, and MPPT inefficiencies.
- **Complex System Design** - Solar designers and installers must engineer around many constraints, often resulting in less than optimal systems. For instance, string voltage is bound by a specific inverter’s minimum and maximum permissible voltage. Further, in addition to physical constraints on the roof, strings must be connected in parallel, on the same facet and with the same orientation, and be of identical length, or else more inverters are required.
- **Insufficient Monitoring** - Traditional systems lack sufficient monitoring and analysis capabilities, as well as critical safety features. Once installed, it is difficult to tell if all modules are functioning optimally.
- **Safety Hazards** - The systems can pose risks to workers installing or maintaining traditional systems, as well as to firefighters dealing with fires in the vicinity of a PV installation.
- **Limited Scaling, Retrofit and Repair** - Because of module mismatch issues, installers are extremely limited in the selection of modules they can use to replace broken systems, or add to existing systems. Module manufacturers must store modules for years to ensure they can meet warranty requirements.

As a result, solar installations cost more and do not produce at maximum efficiency. They pose installation and maintenance hazards, and they provide limited – if any – monitoring and feedback. While some companies are tackling improvements of various aspects of photovoltaic systems, there has been no holistic approach to address these problems. Until now.



SolarEdge Technologies presents a unique, patent-pending distributed power harvesting system, combining more efficient power harvesting, a highly-reliable inverter, and comprehensive module-level monitoring. The SolarEdge system offers significant improvements over existing solutions:

- Optimized power output from each module, regardless of adjacent module performance
- Module-level monitoring and installation feedback
- Easier system design
- Optimal space utilization of any given site
- Quick installation and commissioning
- Cost savings on wiring, diodes, fuses and other hardware
- Superior safety features for installers and firefighters

This paper presents an overview of the innovative SolarEdge distributed power harvesting system, and explains the advantages for an integrator/installer over traditional solar elements.

The SolarEdge Difference

By introducing a distributed power harvesting architecture, SolarEdge overcomes the limitations present in current PV systems and allows for many more benefits. SolarEdge introduces module-level electronics that insulate the overall system from the many changes occurring in each module. The SolarEdge system is comprised of three key technologies:

- **SolarEdge PowerBox™ module-integrated distributed power harvesting** - The SolarEdge PowerBox™ is integrated into each module, replacing the traditional junction box. The PowerBox optimizes energy output and enables monitoring of each individual module. Further, each string's PowerBoxes automatically maintain a fixed string voltage, giving installers greater flexibility to design optimal PV systems.

- **SolarEdge Inverter** - The SolarEdge inverter is a highly reliable inverter. Because MPPT and voltage management are handled separately for each module, the inverter is only responsible for DC to AC inversion. Consequently, it is a less complicated, more reliable device. The fixed string voltage ensures operation at the highest efficiency at all times, independent of string length and temperature.
- **SolarEdge Monitoring** - A web-based software system provides module-level, string-level and system-wide monitoring. The software automatically provides alerts on a wide range of issues affecting energy generation that might otherwise go undetected. SolarEdge monitoring can be deployed in conjunction with the PowerBox, or separately to monitor existing solar installations.

Figure 1 illustrates a typical SolarEdge PV system.

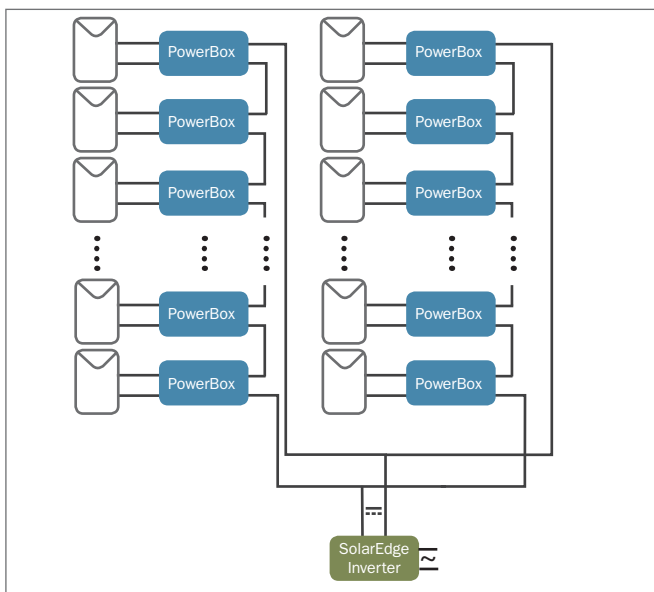

Figure 1: SolarEdge system installation

It is important to note that the module-module connections remain DC connections. The SolarEdge solution does not utilize AC-modules or micro inverters – solutions that have high cost, relatively low reliability and lower conversion efficiency. Moreover, the SolarEdge installation procedure is identical to that of existing solutions, minimizing the installer's learning curve while adding many tools that simplify installation and debugging of the system.

SolarEdge Feature Overview

SolarEdge PowerBox™ Features

The SolarEdge PowerBox replaces the junction box on each solar module. A PowerBox can be retrofitted onto existing modules, and is also available from SolarEdge design partners pre-integrated into modules.

The PowerBox has four key functions: optimizing power harvesting with module-level MPPT tracking, communicating performance data, maintaining a fixed string voltage, and turning off the voltage when safety is needed. As we will see, this functionality gives the installer far greater flexibility to design an optimal system. Each PowerBox is powered by its module, and does not require a separate power supply.

Module-level MPPT - A highly-optimized algorithm ensures each module is kept in MPP, preventing power loss even in module mismatch or partial shading conditions. Module-level MPPT is faster and more responsive than tracking done at the inverter, and enables other benefits. SolarEdge's faster maximum power point tracker is able to follow changes in sun irradiance more precisely and efficiently than classic trackers. This agility ensures that no power is lost on partially cloudy days when changes in irradiance are frequent and fast.

Performance Tracking and Communication - Each PowerBox communicates with the inverter and the SolarEdge monitoring system, conveying a range of module-specific status indicators including: unique ID, amount of power produced, module voltage, current, and so forth. SolarEdge telemetry is unique, as the data is transmitted over existing DC power lines, eliminating the need for additional wiring.

Fixed String Voltage - Traditional systems have held solar designers hostage to the very specific parameters of modules and inverters. The system must contain enough modules to meet the minimum voltage requirements of the inverter, yet not exceed its maximum permitted voltage, regardless of the system's constantly changing environment.

One of SolarEdge's breakthroughs is that the PowerBoxes are able to maintain a fixed string voltage, and maintain it at the optimal point for DC-AC conversion by the inverter. Each PowerBox uses DC-DC conversion and all of them work together to ensure the string voltage is constant, regardless of the number of modules in a string and of the performance of each module. (See the section Concept of Operation for a detailed example.)

Fixed string voltage offers many benefits:

- **Flexible Deployment** - It is possible to serially connect mismatched power sources, such as mismatched solar modules, panels of different models and power ratings, and even modules from different manufacturers.

The number of modules in the system is limited only by the rated power of the inverter, and the number of modules in a single string can range between 6 to 25 units in a 1-phase system (10 to 50 in a 3-phase), according to installer preference on site. Parallel strings may be of different length, orientation, and power rating.

- **Reduced Installation Cost** - The SolarEdge architecture lets installers build longer strings with less wiring, as well as fewer connection and combiner boxes, reducing the total installation cost and labor. Additionally, SolarEdge PowerBoxes have an increased fuse rating, so an installation needs fewer fuses, wiring and other non-inverter BoS elements. This cost reduction obviously becomes more significant as the system gets larger.

- **Temperature Indifference** - With traditional PV systems, the voltage increases and decreases with the outside temperature. Installers design the string length so that it is not too long (for cold days) and not too short (for hot days). This often clumsy process requires specialized string sizing software, and increases the likelihood that mistakes will be made. The result: less than optimal utilization of roof real estate. The SolarEdge constant string voltage completely removes the temperature constraints.



Improved Safety - All modules start up in "Safety mode" until the inverter is initialized. In "Safety mode", the PowerBox devices remain in a very low-voltage state. The system will remain in this state until it is connected to a functioning SolarEdge inverter. Consequently, as long as the system is in "Safety mode", the installer has no risk of electrocution throughout the installation process, because no dangerous voltage occurs until the system is fully installed. Moreover, in the event of a grid power shutdown, the solar modules immediately stop producing power and revert to this safe mode. This is beneficial to firefighters trying to extinguish a fire in a house equipped with a SolarEdge PV installation and to PV maintenance personnel. They need not worry about high DC voltages: once AC power is cut, all voltage shuts down and the installation is safe.

Of importance to module manufacturers, each PowerBox™ contains an integrated flash-test bypass mechanism, ensuring they can use the industry standard flash test with no need for adaptations to their production line.

Finally, SolarEdge understands that product reliability is critical for market acceptance. To ensure we reach quality goals, a two-tiered approach has been taken: The PowerBox products are designed and tested to function for 25 years under harsh environmental conditions. Further, a passive reliability bypass is embedded within each PowerBox, guaranteeing that a failure in a PowerBox or its connected module will not have a wide-spread effect.

SolarEdge Inverter Features

SolarEdge offers a range of inverters to meet the needs of both residential and commercial solar installations. Because the SolarEdge system distributes power harvesting and complex MPPT capabilities to each module, the inverter can be a fairly simple device. Features include:

- **Optimal Efficiency** - The SolarEdge inverter does not need to track maximum power, so it does not lose power when the sun irradiance changes (unlike the slow tracking ability inherent in traditional inverters.) Traditional inverter efficiency depends on input voltage, and thus these inverters do not always operate at their advertised efficiency.

With the SolarEdge power harvesting system, the inverter input voltage is always fixed. This constant input voltage guarantees that the inverter is always operating at the highest possible efficiency point, independent of string length or environmental conditions. Not only does the higher efficiency produce more power, it also reduces heat dissipation, lengthens component lifetime and improves reliability.

- **High Reliability**- In traditional systems, the voltage input to the inverter can fluctuate greatly with string length, temperature, and illumination of the modules, and can reach voltages as high as 1000V. In the SolarEdge system, the input voltage is fixed and can be controlled to lower voltages. Thus, the inverter electronics operate under less stress and can be better de-rated to function well below their long-term damage states.
- **Advanced Communication Options** - A built-in receiver for PowerBox transmissions allows reception of module level telemetries over the DC lines. Integrated Ethernet enables easy broadband connection to the monitoring server. Other communication options include ZigBee wireless communication and RS485 to permit communication between inverters.

- **Small Outdoor Enclosure** - Allows easy installation in any location. The inverter's compact and lightweight bracket-mounted design helps reduce installation time and effort.
- **Support for Third Party Inverters** - Third party inverters can also be used, though some SolarEdge features may not be available.

SolarEdge Monitoring Portal Features

SolarEdge provides a comprehensive, hierarchical monitoring system that tracks system, string and module-level performance. SolarEdge offers two versions of its monitoring system: fully integrated, for use in conjunction with the SolarEdge PowerBox, and a standalone monitoring package that will easily integrate with non-SolarEdge modules.

The SolarEdge Monitoring Portal tracks the technical and financial performance of one or more SolarEdge photovoltaic sites. The Portal provides accurate information about each individual module and about the system as a whole. This enables installers and site owners to quickly detect, pinpoint and troubleshoot faults, efficiently manage maintenance operations, and analyze site profitability.

Smart algorithms continuously track the power, voltage and current from all modules and inverters, as well as a range of statistical and meteorological indicators to detect suboptimal performance or events that require intervention or maintenance.

The SolarEdge Monitoring Portal provides near real-time data, as well as aggregated, historical information. Further, the system provides diagnostics for comparative analysis, and a unique, guided utility to help identify the root-cause of any problem. The SolarEdge Portal automatically detects problems, issues status reports and alerts, and provides recommendations and suggested solutions. All the data is logged and can be securely reviewed and analyzed at any time from any location.

These features enable installers, integrators, maintenance staff, and owners to improve the site performance and reduce maintenance costs by increasing system uptime and resolving faults more quickly.

The SolarEdge Monitoring Portal is accessible via a standard Internet browser, and allows interaction with the PV system through a multi-tiered interface that is friendly enough for residential users and sophisticated enough to be of assistance to the most advanced installers and commercial site managers.

The SolarEdge Monitoring Portal does not require any installation or download of special plug-ins.

Features of the Monitoring Portal include:

- **Accurate Fault Detection** - Not only does the SolarEdge system provide comprehensive detail about performance, trends, and maintenance, but SolarEdge incorporates artificial intelligence to provide context and analysis. For instance, the SolarEdge system can interpret data and determine that a power loss is occurring, and inform the user that the cause is partial shading. This helps installation and maintenance staff quickly pinpoint any issues.
- **Fast Troubleshooting** - Interactive charts and site layout maps make it easy for installers to ensure a system is functioning properly after installation, and quickly identify problems if they arise.
- **Customized Automatic Alerts** - Users can identify the level of detail they wish to receive from the system. Alerts can be sent via SMS, email or through the Monitoring Portal.
- **Powerful Embedded Reporting Tools** - SolarEdge reporting summarizes all key data, including financial performance, energy production, and environmental benefits. Additionally, should a maintenance issue arise, the system can provide details about its financial impact. This will assist maintenance staff in assessing the priority for repairs.
- **Solar Field Maintenance Tools** - Maintenance staff can create a consolidated view of all open issues for a given site or set of sites. Not only will SolarEdge provide this summary, but the system will also offer recommended actions to resolve each issue, pinpoint the location of the related components at the site, and provide the history of each component's previous maintenance events.



- **Maintenance History** - A full history of activity at each site is maintained automatically, including current status, actions taken, and closure of incidents. This allows site owners/maintenance staff to effectively track the installation throughout its lifecycle.
- **Multi-Tiered Interface** - Monitoring can be configured to control the information that is presented based on the credentials of the user. For example, an installer or integrator can manage a full view of all modules and alerts, while a homeowner is able to see basic performance information.

Monitoring for Existing PV Sites

SolarEdge also offers a monitoring solution for existing PV sites not currently using SolarEdge-enabled modules. This easy-to-install package is ideal for large solar farms and commercial installations, and provides comprehensive string and system-level monitoring. Monitoring data is transmitted over the existing power lines, so added wiring is not required. Components include:

- **SolarEdge Probe** - A single SolarEdge Probe is connected to each string of modules. Each probe measures the performance of its string.
- **SolarEdge Bridge** - A SolarEdge Bridge groups clusters of strings. Each Bridge measures the performance of its clusters, while also collecting the string performance data that has been measured by SolarEdge Probes and transmitted to the Bridge over the power lines. All cluster and string performance data is wirelessly sent by the Bridges to the SolarEdge PoleStar.
- **SolarEdge PoleStar** - The SolarEdge PoleStar wirelessly collects monitoring data from all the Bridges. In addition, the PoleStar monitors the performance of the inverters in the site, be it SolarEdge Inverters, or non-SolarEdge inverters.

Monitoring data from the entire site is then securely sent by the PoleStar to the remote SolarEdge server through the Internet, where it can be accessed through the SolarEdge Monitoring Portal.

Concept of Operation

In order to illustrate the operating principles of the SolarEdge system, let's review an example of system behavior under varying conditions.

The system, shown in Figure 2, consists of 10 200W modules. Each of these modules has an integrated PowerBox DC/DC MPPT controller, and the PowerBoxes are serially-connected to form a single string.

The string is connected to a SolarEdge inverter. The SolarEdge inverter is a single stage current source – it continuously adapts the current it draws from the PV array in order to keep the input voltage constant.

The SolarEdge PowerBox is highly efficient – maintaining over 98% conversion efficiency over a wide range of conditions. However, for simplicity, let's assume in this example that each PowerBox has 100% efficiency.

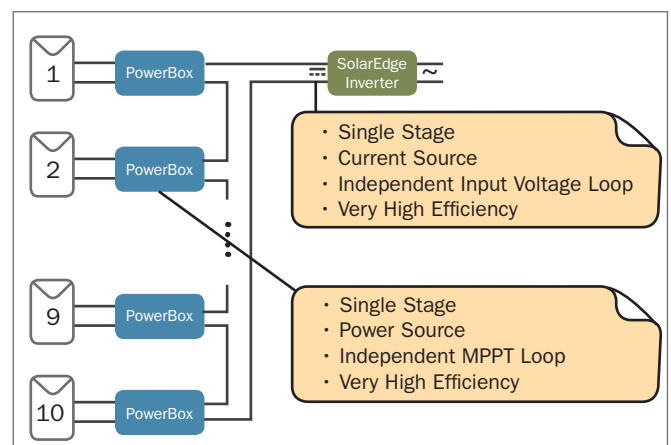

Figure 2: System elements

Scenario 1 - Full Sun: For our first example, let's assume all of the modules are exposed to full sun irradiance, and each module is providing 200W of power. The power output of each solar module is maintained at the module's maximum power point by a control loop within the corresponding PowerBox. This MPPT loop will dictate an input current I_{in} and input voltage V_{in} to the PowerBox that will ensure the transfer of the entire 200W from the module to the DC bus. Let us assume the MPPT for each module (assuming perfectly matched modules for demonstration purposes) is $V_{MPP} = 32V$. This means that the input voltage to the PowerBox would be 32V, and the input current would be $200W/32V = 6.25A$.

As noted in Figure 2, the input voltage to the inverter is controlled by a separate feedback loop. In this example, the inverter will receive a constant 400V - which is the optimal voltage for inversion to the grid AC voltage.

Since there are ten serially-connected modules, each providing 200W, the input current to the inverter is $2000W/400V = 5A$. Thus, the DC bus current flowing through each of the PowerBox units must be 5A. In this example, this means that each PowerBox provides an output voltage of $200W/5A = 40V$.

In this case, the PowerBoxes are acting as up converters, converting the 32V input voltage to the target 40V output voltage. The various currents and voltages in the system are illustrated in Figure 3.

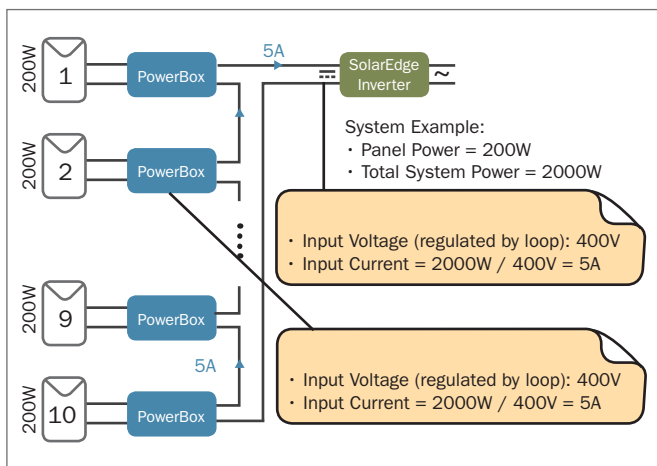

Figure 3: Operation under ideal conditions

Scenario 2 - Partial Shading: Next, let's assume module number 9 is shaded and consequently produces only 40W of power. The other nine modules are un-shaded and each still produces 200W of power. The PowerBox of the shaded module maintains that module at its maximum power point, which is now lowered due to the shading – assuming $V_{MPP} = 28V$, the current is $40W/28V = 1.43A$.

The total power produced by the string is now $9 \times 200W + 40W = 1840W$. Since the input voltage to the inverter will still be maintained at 400V, the input current to the inverter will now be $1840W/400V = 4.6A$. This means that the DC bus current must be 4.6A. Therefore, the PowerBox units of the nine un-shaded modules will have an output of $200W/4.6A = 43.5V$.

On the other hand, the PowerBox attached to the shaded module will output $40W/4.6A = 8.7V$. Doing the math, the input to the inverter can be obtained by adding nine modules providing 43.5V and one module providing 8.7V, i.e. $9 \times 43.5V + 8.7V = 400V$.

In this case, the 9 PowerBox units producing 200W each are essentially acting as up converters, converting the 32V input voltage to a 43.5V output voltage, whereas the tenth PowerBox (of module 9) is acting as a down converter, converting the 28V input voltage to a 8.7V output voltage.

The various currents and voltages in the system are illustrated in Figure 4.

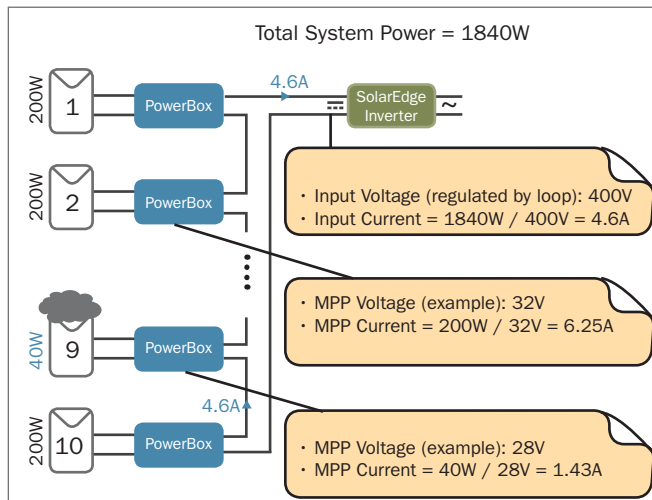

Figure 4: Operation with partial shading

As this example demonstrates, each of the modules is operating at its maximum power point, regardless of the operating conditions.

A comparison of the system operation in the optimal case and in the shaded case can be seen in Figure 5.

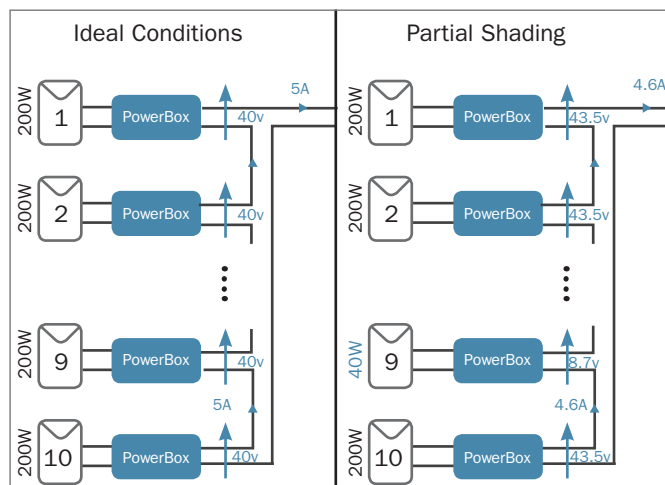

Figure 5: Case comparison

Note that both up and down DC/DC conversion are automatically used, depending on the environmental conditions.



System Benefits

SolarEdge power harvesting systems offer substantial benefits to all participants in the value chain – module manufacturers, system integrators, installers, and site owners.

More Power - Optimized MPPT per module delivers up to 25% more power, due to higher tolerance to shading, manufacturing tolerance compensation, and better MPPT tracking.

Simple System Design and Full Roof Utilization - There is no longer a need for complicated string length calculations. Installers can now build strings of different lengths (between 6 and 25 modules in a 1-phase system) to optimize roof real estate. Further, there is no need to match the string lengths – a 6-module string and a 25-module string can be connected in parallel to the same inverter. Additionally, SolarEdge supports different module orientations, so south-facing modules may be connected to west-facing modules without requiring an additional inverter. All of these capabilities make for faster design and implementation.

Less Wiring and Other BoS Components - SolarEdge makes it possible to build longer strings with fewer inverters, reducing wiring, combiner boxes, and other components. The PowerBox raises fuse ratings, allowing the use of fewer fuses. Further, there is no need to place reverse current diodes in each string.

Scalable Installation - Adding modules to existing installations is simple and straightforward, so installers can expand systems as needed. Moreover, SolarEdge makes it possible to combine different module models. For example, 180W modules can now be connected to 220W modules, allowing installers to speed their installations by leveraging available inventory.

Improved Inventory Management

Module manufacturers also benefit. Because SolarEdge systems can accommodate modules of different power levels, manufacturers can ship full systems with different powers. Furthermore, the need to maintain modules in inventory for decades to address additional module orders or warranty repairs is eliminated.

Monitoring, Maintenance and Serviceability -

SolarEdge supports module-level monitoring and communication over the existing power lines, without additional wires. This enables continuous tracking of each module's performance and also allows for easy troubleshooting during installation and ongoing maintenance.

Reduced Installation Time - due to easier design and troubleshooting, installations can be up and running faster so installation labor costs are reduced by 15% - 25%, meaning improved profitability and efficiency for installers.

Improved Safety - PowerBox electronics guarantee that the modules produce a safe DC voltage until properly connected to a functioning inverter. This is beneficial to installers, who may work safely without worrying about electrocution. It is also important to firefighters, as they can now be assured that the PV system no longer carries high voltage as soon as the SolarEdge inverter is disabled or AC is disconnected to the house.

Theft-Prevention - The SolarEdge PowerBox has unique capabilities that can detect theft attempts, and ensure the modules cannot be used if they are stolen.

Module Production Line Improvement - The market trend in today's PV systems is toward larger currents, using wiring with the highest possible ampacity. Use of SolarEdge systems allows module manufacturers to get higher currents from existing modules, rather than investing in new production lines with larger cells.

Conclusion

The SolarEdge patent-pending distributed power harvesting system offers a broad range of benefits for all players in the solar industry. Although there are other solutions focused on improving different aspects of photovoltaic systems, we believe the SolarEdge solution to be the most reliable, cost effective, and complete solution in the market. Solar installations powered by SolarEdge are able to harvest up to 25% more energy, while providing improved safety, reliability, and comprehensive monitoring at a lower cost than competing solutions.



solaredge

About SolarEdge

SolarEdge provides next generation power conversion electronics that effectively remove all known system constraints across the photovoltaic energy space. Our Smart DC technology enables increased production of clean, grid-ready energy at a lower cost per watt than any other competitive offering.

SolarEdge technology marries traditional photovoltaic workflows and installation methods with a groundbreaking holistic system approach. It is a quiet revolution that is at once disruptive because of its profound benefits in changing the manner in which energy is harvested, deployed, managed and delivered and complementary because it fits into the current photovoltaic workflow.

At SolarEdge we believe the PV delivery chain is ultimately only as strong as its weakest link. By adopting a “system first” philosophy that identifies and eliminates the Achilles heel in each step in the process, we enable a constraint-free delivery of sun harvested energy.

USA 2225 East Bayshore Rd., Suite 200, Palo Alto CA 94303, USA

Germany Königstr. 5, 01097 Dresden, Germany

Japan B-9 Ariake Frontier Building, 3-7-26 Ariake, Koto-Ku, Tokyo 135-0063, Japan

Israel 6 HaHarash St. P.O.Box 7349, Neve Neeman, Hod Hasharon 45240, Israel

www.solaredge.com

© Copyright SolarEdge. 2009. All rights reserved. SolarEdge, the SolarEdge logo, PowerBox and architects of energy are trademarks or registered trademarks of SolarEdge, Ltd. All other trademarks mentioned herein are believed to be trademarks of their respective owners.
Date: 04/2010

architects of energy™