



Export Limitation Application Note

Version 2.8

Disclaimers

Important Notice

Copyright © SolarEdge Inc. All rights reserved.

No part of this document may be reproduced, stored in a retrieval system or transmitted, in any form or by any means, electronic, mechanical, photographic, magnetic or otherwise, without the prior written permission of SolarEdge Inc.

The material furnished in this document is believed to be accurate and reliable. However, SolarEdge assumes no responsibility for the use of this material. SolarEdge reserves the right to make changes to the material at any time and without notice. You may refer to the SolarEdge web site (www.solaredge.com) for the most updated version.

The material furnished in this document is believed to be accurate and reliable. However, SolarEdge assumes no responsibility for the use of this material. SolarEdge reserves the right to make changes to the material at any time and without notice. You may refer to the SolarEdge web site (<https://www.solaredge.com/us/>) for the most updated version.

All company and brand products and service names are trademarks or registered trademarks of their respective holders.

Patent marking notice: see <http://www.solaredge.com/patent>
<https://www.solaredge.com/us/patent>

The general terms and conditions of delivery of SolarEdge shall apply.

The content of these documents is continually reviewed and amended, where necessary. However, discrepancies cannot be excluded. No guarantee is made for the completeness of these documents.

Please note: This product is intended to provide remote shutdown of the SolarEdge PV harvesting system, to enable safer access to a building in the event of fire. This product DOES NOT reduce the risk of fire or protect firefighters or others accessing a building in the event of a fire.

If the RS485 communication between the firefighter gateway and the SolarEdge inverter(s) is disconnected for any reason (including fire), the firefighter gateway LCD will display "No Communication" or "Partial Com.". In this case, the firefighter gateway cannot be relied upon to disconnect the SolarEdge PV harvesting system.

The images contained in this document are for illustrative purposes only and may vary depending on product models.

FCC Compliance

This equipment has been tested and found to comply with the limits for a Class A digital device, pursuant to part 15 of the FCC Rules.

Emission Compliance

This equipment has been tested and found to comply with the limits applied by the local regulations.

These limits are designed to provide reasonable protection against harmful interference. This equipment generates, uses and can radiate radio frequency energy and, if not installed and used in accordance with the instructions, may cause harmful interference to radio communications. However, there is no guarantee that interference will not occur in a particular installation. If this equipment does cause harmful interference to radio or television reception, which can be determined by turning the equipment off and on, you are encouraged to try to correct the interference by one or more of the following measures:

- Reorient or relocate the receiving antenna.
- Increase the separation between the equipment and the receiver.
- Connect the equipment into an outlet on a circuit different from that to which the receiver is connected.
- Consult the dealer or an experienced radio/TV technician for help.

Changes or modifications not expressly approved by the party responsible for compliance may void the user's authority to operate the equipment.

NOTE



Interference may occur when the Wi-Fi Plug-in and Repeater are installed near other 2.4 GHz emitting devices (such as dual technology PIR detectors used in alarm systems, microwave ovens, etc.). This might degrade/ disable the gateway/ repeater operation. If possible, avoid installation nearby such devices, or consider these interferences when troubleshooting.

Revision History

Version 2.8 (March 2022)

- "SolarEdge Energy Net" was renamed "SolarEdge Home Network".

Version 2.7 (October 2021)

- Excluding use of Smart Energy Manager (SEM) on follower inverters in multiple-inverter systems.

Version 2.6 (July 2021)

- Support for SolarEdge Energy Net connectivity.

Version 2.5 (September 2020)

- Merged North American and Rest-of-World versions
- SetApp support for export limitation configuration and verification
- MySolarEdge support for export limitation verification

Version 2.4 (January 2019)

- Added Minimum Import appendix
- Added appendix with regional considerations
- Export limitation support for AC-coupled batteries
- Added information on export limitation response time
- Removed support for meters with S0 interface

Version 2.3 (December 2017)

- Removed clustering support.

Version 2.2 (November 2017)

- ZigBee support for communications between inverters discontinued.
- Removed per phase option for single phase inverters.

Version 2.1 (September 2017)

- Support for minimum import settings when required by utility.
- Inepro meter support for export limitation.
- Added clustering support
- Added information on export limitation response times.
- Updated meter definitions: Production, inverter production, site production.

Version 1.0 (February 2016)

- Initial version.

Contents

Disclaimers	1
Important Notice	1
FCC Compliance	2
Emission Compliance	2
Revision History	3
Chapter 1: Introducing Export Limitation	5
Terminology	6
Chapter 2: Connection Options	8
Meter Types and Installation Considerations	9
Single Inverter System	10
Multiple Inverter System	12
EV Charging and Storage Systems	14
Export Limitation Response Time	15
Chapter 3: Export Limitation Configuration	16
Configuring Export Limitation	16
Verifying Export Limitation	19
Appendix A: Monitoring Platform - Meter Data	23
Appendix B: Actual Zero Export Limitation Use Cases	25
Introducing Zero Export Limitation	25
Theory of Operation	26
Example 1 - Periodic Energy Export Limit	28
Example 2 - Export Power Convergence Time Limit	29
Example 3 - Sample Commercial Site Monthly Export Log	30
Appendix C: Examples of Total and Per Phase Export Limitation	32
Example 1 - Single Phase, Zero Export Limit, Total Limit Mode	33
Example 2 - Three-Phase, 70% Export Limit, Total Limit Mode	35
Example 3 - Three Phase, Zero Export Limit, Per Phase Limit Mode	38
Example 4 - Three Phase, 3kW Export Limit, Per Phase Limit Mode	41
Appendix D: Minimum Import	44
Configuring minimum import using SetApp	44
Configuring minimum import using the device display	45
Appendix E: Regional Considerations	46
Hawaii	46

Chapter 1: Introducing Export Limitation

SolarEdge Smart Energy Management solutions allow for increased self-consumption in a PV installation. One method used for this purpose is export limitation, which allows the installation of a larger PV system or a larger inverter without violating grid export (feed-in) limitations.

For export limitation, a SolarEdge device - an inverter or a CCG (Control & Communication Gateway) - dynamically adjusts the PV power production in order to ensure that exported power does not exceed a preconfigured limit. To enable this functionality, an energy meter that measures export or consumption must be installed at the site.

To use export limitation, the inverter/Commercial Gatewaycommunication board firmware (CPU) version must be 2.8xx/3.8xx or higher. If the CPU version is lower, contact SolarEdge support for an upgrade file and instructions (support@solaredge.com).

This document describes system setup considerations and how to configure the system for export limitation.

Terminology

The following terms are used in this document:

- **Export:** The power injected to the grid.
- **Import:** The power purchased from the grid.
- **Export/Import meter:** A meter that is installed at the grid connection point and measures the energy/power exported/imported to/from the grid.
- **Consumption:** The power consumed at the site. Consumption power is calculated as the sum of self-consumption power and import power.
- **Consumption meter:** A meter that is installed at the load consumption point and measures the energy/power consumed by the site.
- **Self-consumption:** The PV power consumed by the site and not fed into the grid.
- **Production:** The power produced by the PV system.
- **Production meter:** A meter that is installed at the inverter output or site AC connection, or inside the inverter (a built-in revenue grade meter), and measures the energy/power produced by the PV system or site.
- **External production meter:** A meter that is used for production metering of 3rd party generators, or for AC coupling with non-SolarEdge inverters.
- **Site production meter:** A meter that is installed at a SolarEdge inverter output, and reads the energy produced by all the inverters at the site.
- **Site limit:** The power level (in kW) that the inverter falls back to once an export limit event is triggered.

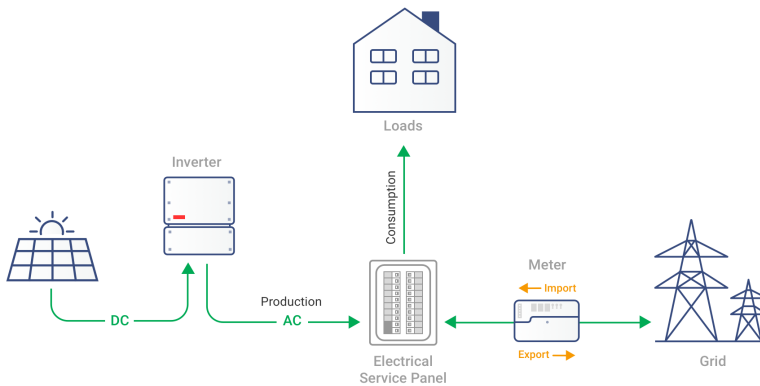

Figure 1: Terminology Illustration

Three-phase grid configuration types:

- **Wye:** In a Wye ("Y") configuration, all three phases are connected at a single neutral point. Wye systems utilize five wires - three hot, one neutral and one ground.
- **Delta:** In a Delta configuration, the three phases are connected in a triangle. Delta systems utilize four wires - three hot and one ground.

Chapter 2: Connection Options

Export Limitation is managed either by an inverter or by a Commercial Gateway, which is the site's smart energy manager. The inverter/Commercial Gateway reads the exported power from a meter installed at the grid connection point or reads the consumption from a meter installed at the load consumption point, and adjusts PV power production according to the preconfigured limit.

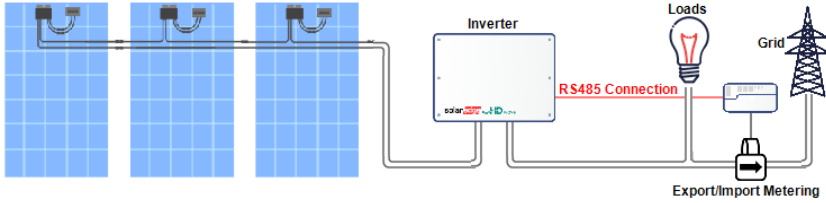

Figure 2: Typical installation with export meter

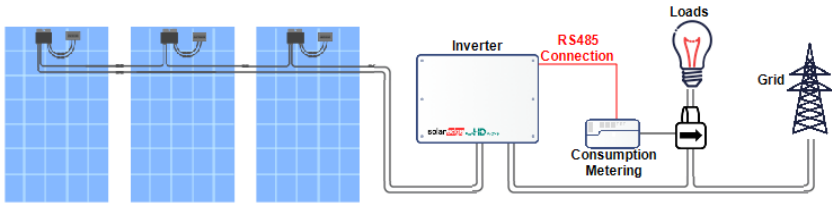

Figure 3: Typical installation with consumption meter

The following sections describe common export limitation connection scenarios and response times.

Meter Types and Installation Considerations

Total and per-phase power measurements and direction can be provided by:

- Meters with an RS485 interface, which are connected to the RS485 port of an inverter/Commercial Gateway
- Meters supporting SolarEdge Home Network, which are connected wirelessly to an inverter.

RS485-Interface meters and SolarEdge Home Network meters can be installed in the following locations:

- For export/import metering: at the grid connection point.
- For consumption metering: at the load consumption point.

The meter should measure all grid phases or consumption phases. When a single-phase inverter is connected to a three-phase grid - a three phase meter is required.

For SolarEdge meter installation, refer to the meter installation guide, available on the SolarEdge website at <http://www.solaredge.com/files/pdfs/solaredge-meter-installation-guide.pdf><http://www.solaredge.com/files/pdfs/solaredge-meter-installation-guide-na.pdf>.

For Inepro meter installation (Inepro meter firmware version 1.18 only), refer to the application note at <https://www.solaredge.com/sites/default/files/connecting-revenue-grade-meter-to-solaredge-devices.pdf>.

NOTE

For installations in Australia: According to Energex and Ergon Energy Connection Guideline (reference EX BMS4286 Ver 1.1 and EE STNW1170 Ver 1.1), power limiting devices must meet the following requirements:



- If current transformers or sensors are used, their terminals should be sealed.
- The terminals of the power-restricting relay /management system shall also be capable of being sealed to prevent tampering with connections – this could include a Perspex cover or lockable cabinet that the equipment is housed in.

Sealing equipment is not supplied by SolarEdge.

Single Inverter System

In a single inverter system, the meter is connected to the inverter - which serves as the smart energy manager, using one of the following methods:

- The meter is connected directly to the RS485 port of the inverter.
- The meter is connected to the inverter over SolarEdge Home Network.

If your inverter has a built-in RGM (Revenue Grade Meter), you can connect an external meter for export limitation using one of the following methods:

- For inverters with a display, connect both the RGM and the external meter to the RS485 port.
- For inverters using SetApp, the external meter can be connected to the second RS485 port.

In the event of a communications loss between the inverter and the meter, the inverter's power level falls back to the site limit.

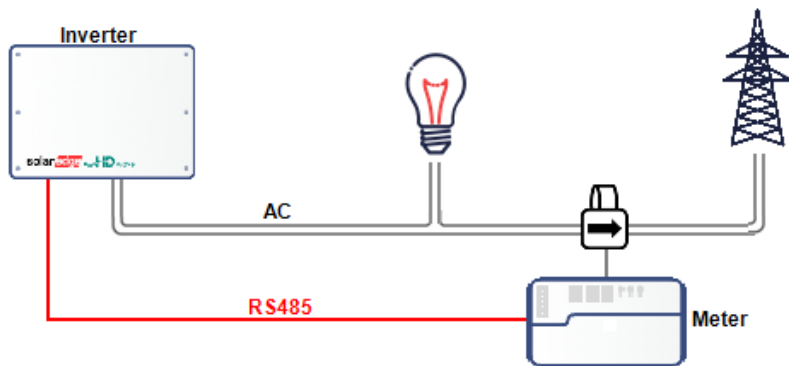

Figure 4: Single-inverter⁽¹⁾ connection with RS485 meter⁽²⁾

⁽¹⁾This figure shows a single phase inverter connection. For three phase inverter 3 CTs are required.

⁽²⁾The figure shows a system with a meter measuring export, but the meter is also applicable to systems with meters measuring consumption.

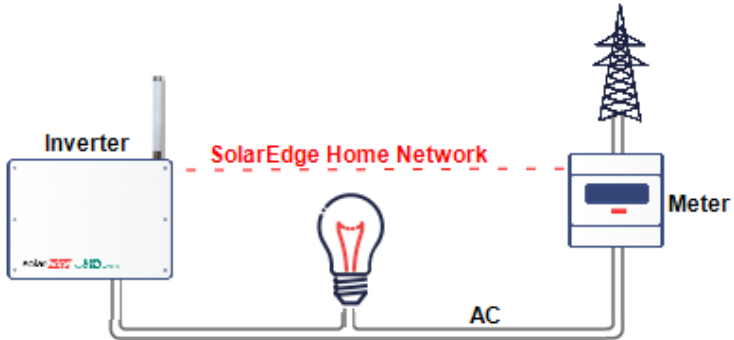

Figure 5: Single-inverter connection with inline meter over SolarEdge Home Network⁽¹⁾

⁽¹⁾The figure shows a system with a meter measuring export, but the meter is also applicable to systems with meters measuring consumption.

Multiple Inverter System

Multiple Inverter System with RS485 Meter

When using an RS485 meter for multiple inverter export limitation, two options are available:

- Option 1: The meter is connected to the RS485 port of the leader inverter, as shown in the figure below. The leader inverter serves as the smart energy manager. If your inverter has a built-in RGM (Revenue Grade Meter), you can connect an external meter for export limitation using one of the following methods:
 - For inverters with a display, connect the meter using the RS485 Expansion Kit (available from SolarEdge).
 - For inverters using SetApp, you can connect both meters to the RS485 port configured as multi-device.

In the event of a communications loss between the inverter and the meter, the multiple inverter system power level falls back to the site limit.

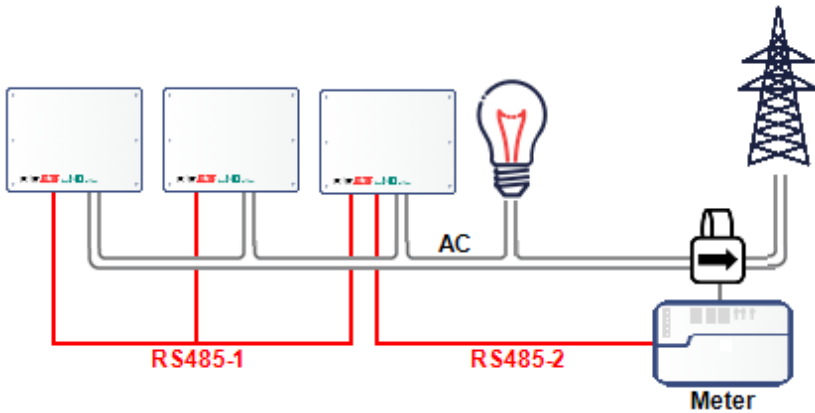

Figure 6: Multi-inverter connection with inverter as Smart Energy Manager

- Option 2: The meter is connected to one of the RS485 ports of a Commercial Gateway, as shown in the figure below. The Commercial Gateway is the smart energy manager. The Commercial Gateway's second RS485 port can be used to create an RS485 bus for communication between the inverters.

In the event of a communications loss between the Commercial Gateway and the meter, the multiple inverter system power level falls back to the site limit.

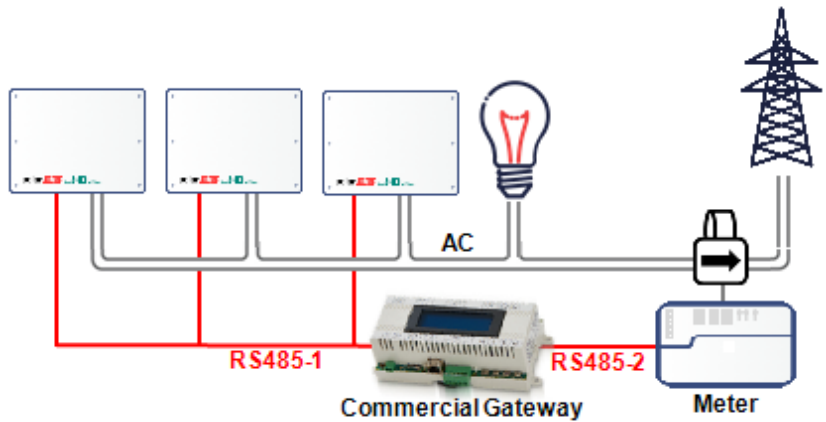

Figure 7: Multi-inverter connection with Commercial Gateway

Multiple Inverter System with Inline Meter Connected via SolarEdge Home Network

When using SolarEdge Home Network to connect an inline meter in a multiple inverter export limitation scenario, the inverter serving as the smart energy manager connects to the meter wirelessly over SolarEdge Home Network.

In the event of a communications loss between the inverter serving as the smart energy manager and the meter, the multiple inverter system power level falls back to the site limit.

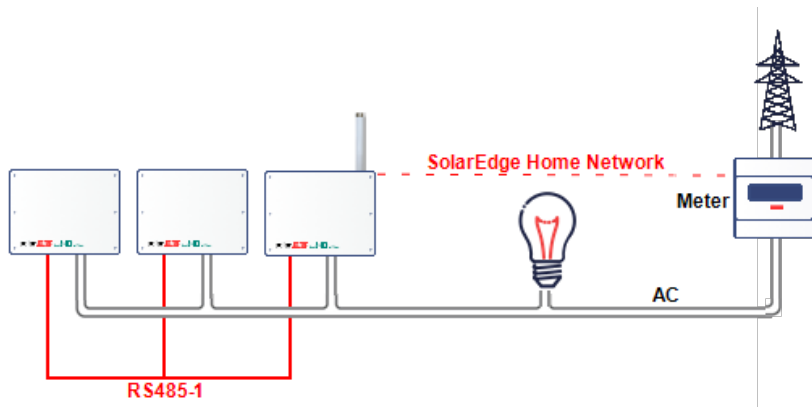

Figure 8: Multi-inverter System SolarEdge Home Network Meter

EV Charging and Storage Systems

Export limitation is supported in EV Charging and Storage systems, subject to the limitations noted in Export Limitation Configuration.

Export Limitation Response Time

The system Export Limitation response time depends on the meter location, on the communication method between the inverters, and on the inverter CPU version:

Meter/ Location	Single Inverter Response Time	Multiple Inverters ⁽¹⁾ Response Time	
		Smart Energy Manager is RS485 Leader or Connected over SolarEdge Home Network	Nested RS-485 Buses ⁽²⁾
Meter at grid connection point (Export/Import Meter)*	≤ 2 seconds	≤ 2 seconds	≤ 3 seconds
Janitza meter at a medium voltage (MV) connection point (response time resolution: 1 second)	≤ 3 seconds	≤ 3 seconds	≤ 3 seconds
Inepro meter	≤ 2 seconds	≤ 2 seconds	N/A
(Virtual) Meter ⁽³⁾	10+ seconds		N/A

(1) Assumes that all inverters produce power at the same level. SetApp inverters can support up to 63 inverters (connected either using 2 RS485 buses or over SolarEdge Home Network).

(2) Nested RS-485 buses are applicable only for display inverters.

(3) The virtual meter provides calculated power/energy values based on actual meter measurements.

Chapter 3: Export Limitation Configuration

This step should be performed after installing and configuring a meter.

In a multi-inverter system, the limit is configured in the Smart Energy Manager (the inverter or Commercial Gateway that is connected directly to the meter).



NOTE

The Smart Energy Manager (SEM) is the device connected to the meter. The SEM is required to be the communication leader.



NOTE

Calculated meter readings (also referred to as "virtual meters"), such as self-consumption, are calculated using the data measured by the meter and the inverters. Virtual meters are only sent when Energy Manager is enabled. If virtual meter information is required, but export limitation is not, the Energy Manager should be enabled without any site limit setting (default).

Configuring Export Limitation

Configuring Using SetApp

► To configure export limitation in the SolarEdge device using SetApp:

1. From the Commissioning page, select **Power Control** → **Energy Manager** → **Limit Control** → **Control Mode** → **Export Control**.
2. Select **Site Limit** and enter the limit value at the connection point, in kW. The default value is none (-), which means that the system is not limited.



NOTE

The value you enter here is the overall limit to which the site export will be restricted, whether you use the Total or Per Phase limit control modes (as explained in the next step).



NOTE

For customers using Hawaiian country settings, solar-only EV charging (Excess Solar mode) is not supported when the export limitation is set to zero. Refer to the appendix, "Regional Considerations" on page 46 for details.

NOTE



Export limitation of an inverter connected to an AC coupled battery is supported in inverter CPU version 3.24xx and higher, provided that the export limitation is > 0 .

3. In the **Limit Control** menu, select **Limit Mode**. Select one of the limit modes displayed below:



- **Total:** The Site Limit is the total export power (the combined production minus the combined consumption) on all the phases combined. Reverse current on one phase will count as negative power and can compensate for another phase.
- **Per Phase:** For three phase inverter connections, the inverter sets the limit on each phase to 1/3 of the total site limit. Use this mode if there is a limit on each individual phase.

For example site limit settings, refer to *Appendix C*.

Configuring Using the Device Display

► To configure export limitation in the SolarEdge device using the device display:

1. Enter Setup mode, and select **Power Control → Energy Manager → Limit Control → Control Mode → Export Ctrl.**
2. Select **Site Limit** and enter the limit value at the connection point, in kW. The default value is none (-), which means that the system is not limited

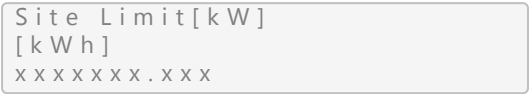

NOTE



The value you enter here is the overall limit to which the site export will be restricted, whether you use the Total or Per Phase limit control modes (as explained in the next step).

NOTE



For customers using Hawaiian country settings, solar-only EV charging (Excess Solar mode) is not supported when the export limitation is set to zero. Refer to the appendix, "Regional Considerations" on page 46 for details.

NOTE



Export limitation of an inverter connected to an AC coupled battery is supported in inverter CPU version 3.24xx and higher, provided that the export limitation is > 0.

3. In the **Limit Control** menu, select **Limit Mode**. Select one of the limit modes displayed below:

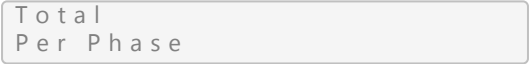

- **Total:** The Site Limit is the total export power (the combined production minus the combined consumption) on all the phases combined. Reverse current on one phase will count as negative power and can compensate for another phase.
- **Per Phase:** For three phase inverter connections, the inverter sets the limit on each phase to 1/3 of the total site limit. Use this mode if there is a limit on each individual phase.

For example site limit settings, refer to *Appendix C*.

Verifying Export Limitation

Verifying Using SetApp

► To verify export limitation operation using SetApp:

1. View the site-level data on the Smart Energy Manager page.

Smart Energy Manager	
Site Limit	7.0 kW
Site Production	10.0 kW
Site Export	4.0 kW
Self-consume	6.0 kW

Site Limit: The limit that was defined for the site.

Site Prod: The power produced by the site.

Site Export: The power that is fed into the grid. This line is displayed only if the control mode is "Export Control".

Self-consume: The PV power consumed by the site. This line is displayed only if the control mode is "Export Control".

2. Check the Power Control status screen of any inverter:

Power Control Status	
PWR Control	Remote
PWR Limit	10.04 kW
Cos Phi	0.9
Power Prod	7000 W

PWR Control: The power control status:

- **Remote** - Communication with the smart energy manager is confirmed/validated. This status should appear in all inverters.
- **Local** - The power is controlled locally (e.g. by a fixed limit), or this inverter limits the PV power production to its relative portion of the export power limit, as a result of disconnected communication with the smart energy manager. If this status appears, check the communication to the smart energy manager or the communication to the meter.

PWR Limit: The inverter maximum output power set by the smart energy manager

Cos Phi: The ratio between active to reactive power

Power Prod: The power produced by the inverter

Verifying Using the Device Display

► To verify export limitation operation using the device display:

1. Press the Enter button or the LCD external button until reaching the Smart Energy Manager status screen, showing the site-level data. View the site-level data on the Smart Energy Manager screen.

```
Site Limit:      7.0 kW
Site Prod:      10.0 kW
Site Export:     4.0 kW
Self-consume:   6.0 kW
```

Site Limit: The limit that was defined for the site.

Site Prod: The power produced by the site.

Site Export: The power that is fed into the grid. This line is displayed only if the control mode is "Export Ctrl".

Self-consume: The PV power consumed by the site. This line is displayed only if the control mode is "Export Ctrl".

2. Check the Power Control status screen of any inverter:

```
PWR CTRL: REMOTE
PWR Limit: 10.04 kW
Cos Phi: 0.9
Power Prod: 7000 W
```

PWR CTRL: The power control status:

- **REMOTE** - Communication with the smart energy manager is confirmed/validated. This status should appear in all inverters.
- **LOCAL** - The power is controlled locally (e.g. by a fixed limit), or this inverter limits the PV power production to its relative portion of the export power limit, as a result of disconnected communication with the smart energy manager. If this status appears, check the communication to the smart energy manager or the communication to the meter.

PWR Limit: The inverter maximum output power set by the smart energy manager

Cos Phi: The ratio between active to reactive power

Power Prod: The power produced by the inverter

Verifying Using MySolarEdge

► To verify export limitation operation using MySolarEdge:

1. Select **Inverter Status** → **Advanced Installer View** → **View detailed inverter status** to display inverter status details. Check the value of the **Power Limit** field.



Appendix A: Monitoring Platform - Meter Data

If your device is connected to the SolarEdge server, you can view the meter's readings in the monitoring platform. Verify that the meter type is set correctly in the Admin page > Logical Layout > Meter details:

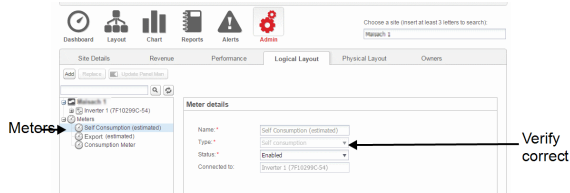

Figure 9: Setting the Meter details in the monitoring platform

Calculated meter readings (also referred to as "virtual meters"), such as self-consumption, are calculated using the data measured by the meter and the inverters.

The data from the inverters and from installed meters is displayed in the Dashboard and Charts tabs of the monitoring platform. The displayed data depends on the meter(s) location: grid connection point (export), or load consumption point (consumption). The following tables detail the displayed information per meter location.

No meter installed:

Data	Displayed in Monitoring Dashboard	Displayed in Monitoring Charts
Production (inverter/site)	✓	✓
Consumption	X	X
Self-consumption	X	X
Export	X	X
Import	X	X

Export meter:

Data	Displayed in Monitoring Dashboard	Displayed in Monitoring Charts
Production (inverter/site)	✓	✓
Consumption	✓ (calculated)	✓ (calculated)
Self-consumption	✓ (calculated)	✓ (calculated)
Export	X	✓
Import	X	✓

Consumption meter:

Data	Displayed in Monitoring Dashboard	Displayed in Monitoring Charts
Production (inverter/site)	✓	✓
Consumption	✓	✓
Self-consumption	✓ (calculated)	✓ (calculated)
Export	X	✓ (calculated)
Import	X	✓ (calculated)

Appendix B: Actual Zero Export Limitation Use Cases

Introducing Zero Export Limitation

A special export limitation use-case exists in which no power is allowed to be exported to the grid, hence the term "zero export". In such a case, the system regulates its production power to match the load's consumption power at all times.

This appendix describes the use cases of zero export limitation and shows examples of system behavior when configured as a zero-export system. However, the same principles apply for non-zero export limitation use-cases. Actual method of configuration can be found in Export Limitation Guide application note.

Theory of Operation

“Zero export” term can be misleading at times as one may think that export to the grid is always avoided. In fact, “zero export” mode is expected to export some energy to the grid in some edge cases. The solar systems strives to produce as much power as possible for the site consumption, however, load change events constantly occur. The zero export-regulated system tries to match production-power and load-consumption-power at all times. During the transition periods, some export power is inevitable.

For the following example, let us assume:

- The load instantaneous consumption power is P_C [W]
- The inverter instantaneous production power is P_P [W]
- The inverter nameplate power is P_{MAX} [W] and is always higher than P_C

In a balanced zero export system, the inverter maintains export power to zero by regulating production power P_P [W] to match P_C [W]. So at the beginning of the above example $P_P = P_C$. At a sudden load power decrease (shedding), the previous instantaneous power (P_C) is changing to $P_{C'}$ (the new instantaneous consumption power). The inverter should abruptly reduce its production power to match the new consumption power ($P_{C'}$): $P_P = P_{C'}$.

During the duration it takes the inverter to reduce its power, energy is temporarily exported to the grid. The energy level exported is a direct result of the following factors:

- The load shedding level ($P_C - P_{C'}$).
- The duration it takes the inverter to apply the above mentioned shedding level, is affected by:
 - The sampling/reading periods associated with the Export/Import meter
 - Communication latencies between the meter and the inverter
 - Communication latencies between inverters (in multiple inverter cases)
 - The duration required by the inverter to throttle down its production power

The blue line in the figure below shows an example of system response times in the case of P_C changing from P_{MAX} to $P_{C'} = 0.33P_{MAX}$ load shedding with one or more inverters (at T1).

The red line represents a single inverter response to the abovementioned load shedding, moving from $P_P (=P_C)$ to $P_{P'} (P_{C'})$. The area between the blue line and red lines (illustrated by the dashed lines) represents the energy exported to the grid during this duration (T3-T1).

The green line represents multiple inverter response to the abovementioned load shedding. The green line will exhibit similar behavior to a single inverter use-case, but will take slightly longer duration (T4-T1) due to the inverters communication latencies.

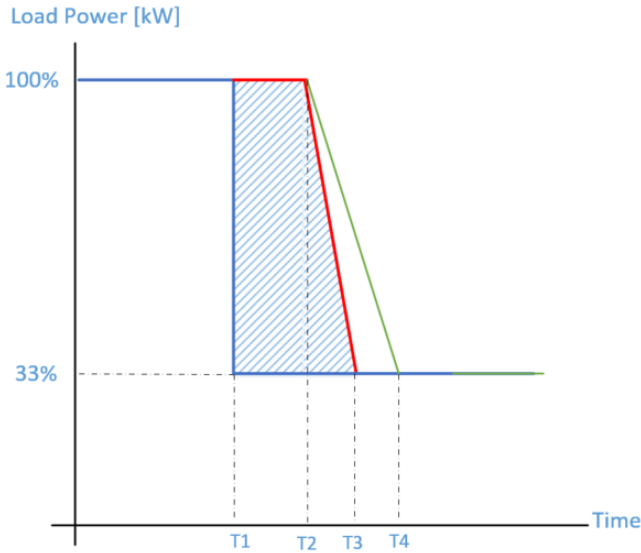









Figure 10: 100% to 33% load shedding

	Power consumed by load
	Power produced by a single inverter system
	Power produced by multiple inverters system

For the general case of load shedding, let us assume:

-  $X = P_C - P_{C'}$ (the load shedding level, in Watts)
-  $T2-T1 \cong 1 \text{ sec}$
-  $T3-T2 \cong 0.5 \text{ sec}$
-  $T4-T3 \cong 0.5 \text{ sec}$

The expected energy export for a single inverter use case is $\sim 1.25X/3600$ [Wh]. The expected energy export for multiple inverters use case is $\sim 1.5X/3600$ [Wh].

Example 1 - Periodic Energy Export Limit

According to Hawaii zero-export regulation, the monthly export energy allowed for a consumer is limited to the inverter’s nameplate in Watt-Hours. In this example, we assume a site in Hawaii with 7.6 kVA inverter, which will be limited to a monthly export of 7.6 kWh.

In the figure below, we can see how a few events contribute to the exported energy level.

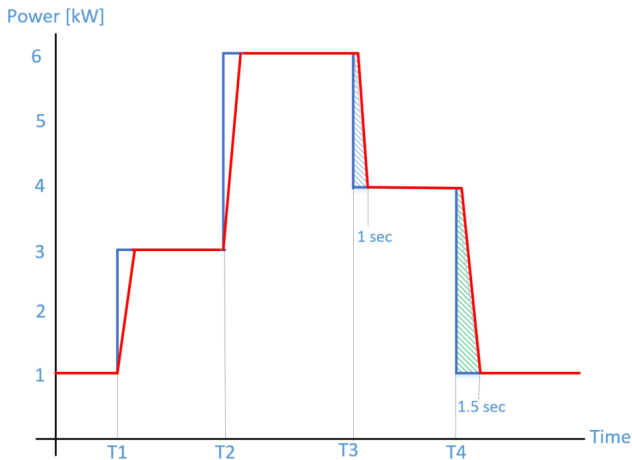



Figure 11: Example 1 – Periodic Energy Export Limit

	Power consumed by load
	Power produced by the inverter

The user turns on 2kW load at T1, and 3kW load at T2. Each time, the inverter regulates its production to match load consumption. Once the user switches OFF the 2kW load at T3, the inverter responds within ~1 second to regulate the power. During this period, energy is exported to the grid (the blue dashed triangle) is ~0.28 Wh. Similarly, once the user switches OFF the 3kW load at T4, the inverter regulates the power within ~2 seconds and the energy exported to the grid (the green dashed triangle) is ~0.83 Wh.

Note: a typical household will generate on average 5 load shedding events per active hour. Assuming the house is active for 6 hours a day and assuming each event exports ~1Wh to the grid; the overall monthly energy exported is ~0.9kWh, which is ~10% of the average inverter nameplate (7.6 kVA).

Example 2 - Export Power Convergence Time Limit

Spain zero-export regulation, requires that any export grid event, will not last for more than 2 seconds, regardless to the exported energy level. For similar general cases, let us assume the duration is T_{Exp} seconds.

In the example depicted below, the first zero export event takes $(t_2 - t_1)$ seconds to reach zero export. According to the regulation requirement, the duration must comply with $(t_2 - t_1) \leq T_{Exp}$. Similarly, the next event must also comply with $(t_4 - t_3) \leq T_{Exp}$.

All SolarEdge inverters comply with the above mentioned regulation. Here is an example:

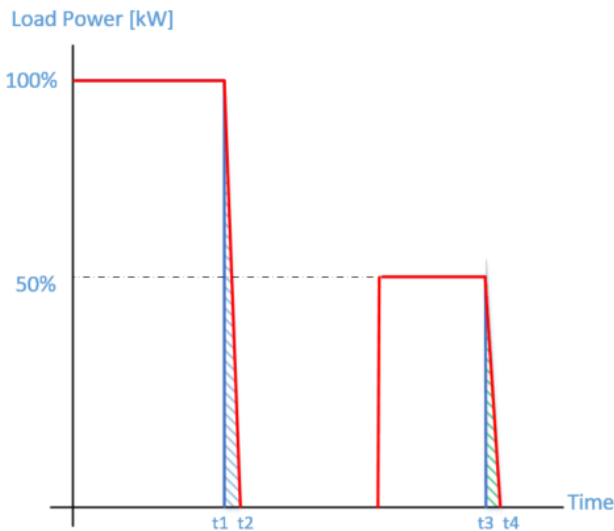

Figure 12: Example 2 – Export Power convergence time limit

—	Power consumed by load
—	Power produced by the inverter

NOTES



- The above mentioned example is valid for both single inverter and multi-inverter cases.
- Some regulations may require a combination of convergence duration and monthly exported power as a mean to enforce zero export.

Example 3 - Sample Commercial Site Monthly Export Log

In this example, we are showing a real system operation and the energy export levels exhibited due to load shedding events. We assume a commercial PV system with 126 unit-level inverters. The table shows the energy exported daily and the daily events count.

Day of the Month	Exported Energy [Wh]	Daily Export Events
1	224	2
2	448	4
3	558	5
4	1,052	8
5	642	5
6	1,144	9
7	754	6
8	1,246	10
9	884	7
10	966	8
11	708	6
12	230	2
13	410	3
14	318	3
15	794	7
16	1,030	8
17	876	7
18	910	8
19	1,312	11
20	1,216	10
21	1,042	8
22	312	3
23	1,338	11
24	1,276	10

25	1,204	10
26	1,282	10
27	1,088	9
28	1,280	10
29	984	8
30	96	1
31	776	7
Total	26,400	216
Daily Average	852	7
Daily average per inverter	7	
Average per inverter per event	1	

The overall system exported energy daily levels depends on the number of inverters. The more inverters, the more energy exported. As mentioned above, the number of events may vary based on user behavior and site characteristics. A factory facility where heavy loads are being switched ON/OFF regularly will exhibit a wide variance of events, while an office building might show a more steady behavior.

Appendix C: Examples of Total and Per Phase Export Limitation

The following examples illustrate the behavior of a system with export limitation when using the **Total** and the **Per Phase** Limit Mode options described in the chapter, *Export Limitation Configuration* on page 16

- **Total:** The Total site limit is the total export power on all the phases combined, that is, the combined production minus the combined consumption, as represented in the formula below. Reverse current on one phase will count as negative power and can compensate for another phase.

$$Export_{total} = \sum_{x=1}^3 Production_{phase(x)} - \sum_{x=1}^3 Consumption_{phase(x)}$$

- **Per Phase (for three phase inverters):** Each phase will be limited to 1/3 of the configured site limit, that is, the export power is the sum of the production minus the consumption of each phase, as represented in the formula below. The division of the limit into the three phases is performed internally; the user enters the total site limit.

$$Export_{PerPhase} = \sum_{x=1}^3 (Production_{phase(x)} - Consumption_{phase(x)})$$

In the example, the Site Limit and Limit Mode configuration is detailed. The example includes production and consumption scenarios and details how the export, consumption and import power values are influenced by the conditions. The tables in each scenario detail the following values:

- Potential PV Production
- Consumption (load)
- Production
- Export power
- Self-consumption
- Import power

In addition, the Smart Energy Management status screen is presented with the values applicable to each scenario.

Example 1 - Single Phase, Zero Export Limit, Total Limit Mode

In this example, the system export power limit is set to 0% of max DC power, that is, no power is fed into the grid, and the **Total Limit Mode** is used.

The example system has a single-phase inverter with a maximum AC power of 7.6 kW.

► To configure export limitation settings:



NOTE

For detailed guidelines on configuring export limitations settings, refer to the chapter, *Export Limitation Configuration* on page 16).

1. Set the Site Limit to 0.0
2. Set the Limit Mode to "Total".

Scenario A

PV potential is greater than the loads.

The loads are powered from the PV.

PV production is not limited, because there is no export power.

	Total power [kW]	Total [kW]
Potential PV Production	7	7
Consumption (load)	4	4
Production	4	4
Export	$\text{Max}(\sum \text{Production} - \sum \text{Consumption}, 0) = \text{Max}(0, 0)$	0
Self-consumption	$\text{Min}(\sum \text{Production}, \sum \text{Consumption}) = \text{Min}(4, 4)$	4
Import	$\sum \text{Consumption} - \sum \text{Self consumption} = 4 - 4$	0

The following Smart Energy Manager status data are displayed:

Site Limit	0.0 kW
Site Production	4.0 kW
Site Export	0.0 kW
Self-consume	4.0 kW

Scenario B

PV potential is lower than the loads.

The loads are powered from the PV and from the grid.

PV production is not limited, because there is no export power.

	Total power [kW]	Total [kW]
Potential PV Production	4	4
Consumption (load)	7	7
Production	4	4
Export	$\text{Max}(\sum\text{Production} - \sum\text{Consumption}, 0) = \text{Max}(-3, 0)$	0
Self-consumption	$\text{Min}(\sum\text{Production}, \sum\text{Consumption}) = \text{Min}(4,7)$	4
Import	$\sum\text{Consumption} - \sum\text{Self consumption} = 7-4$	3

The following Smart Energy Manager status data are displayed:

Site Limit	0.0 kW
Site Production	4.0 kW
Site Export	0.0 kW
Self-consume	4.0 kW

Example 2 - Three-Phase, 70% Export Limit, Total Limit Mode

In this example, the system has 12kW DC power connected to a three-phase inverter with a maximum AC power of 10kW.

The system export power limit is set to 70% of max DC power, that is, to 70% x 12kW = 8.4kW, and the **Total** Limit Mode is used.



NOTE

Systems in Germany complying with the EEG2012 70% limitation would be configured using the Total option.

► To configure export limitation settings:



NOTE

For detailed guidelines on configuring export limitations settings, refer to the chapter, *Export Limitation Configuration* on page 16).

1. Set the Site Limit to 8.4
2. Set the Limit Mode to "Total".

Scenario A

PV potential is greater than the loads, which are not distributed evenly across the 3 phases.

The loads are powered from the PV only, and the excess PV power is fed into grid.

PV production is not limited, because the export power is lower than the limit.

	Phase 1 [kW]	Phase 2 [kW]	Phase 3 [kW]	Total [kW]
Potential PV Production	3.33	3.33	3.33	10
Consumption (load)	3	3	0	6
Production	3.33	3.33	3.33	10
Export	Max (\sum Production – \sum Consumption, 0) = Max(4,0)			4
Self-consumption	Min (\sum Production, \sum Consumption) = Min(10,6)			6
Import	\sum Consumption – \sum Self consumption			0

The following Smart Energy Manager status data are displayed:

Site Limit	8.4 kW
Site Production	10.0 kW
Site Export	4.0 kW
Self-consume	6.0 kW

Scenario B

PV potential is equal to the loads, which are not balanced across the 3 phases.

The loads are powered from the PV only.

Although on phase 1 the consumption is greater than the production, the difference is compensated for by phase 3, where the production is greater than the consumption.

Therefore, PV production is not limited, because there is no export power.

	Phase 1 [kW]	Phase 2 [kW]	Phase 3 [kW]	Total [kW]
Potential PV Production	2	2	2	6
Consumption (load)	3	2	1	6
Production	2	2	2	6
Export	$\text{Max}(\sum \text{Production} - \sum \text{Consumption}, 0) = \text{Max}(0,0)$			0 (no export)
Self-consumption	$\text{Min}(\sum \text{Production}, \sum \text{Consumption}) = \text{Min}(6,6)$			6
Import	$\sum \text{Consumption} - \sum \text{Self consumption}$			0

The following Smart Energy Manager status data are displayed:

Site Limit	8.4 kW
Site Production	6.0 kW
Site Export	0.0 kW
Self-consume	6.0 kW

Scenario C

PV potential is lower than the loads, which are not balanced across the 3 phases.

The loads are powered from the PV and from the grid.

PV production is not limited, because there is no export power.

	Phase 1 [kW]	Phase 2 [kW]	Phase 3 [kW]	Total [kW]
Potential PV Production	1.66	1.66	1.66	5
Consumption (load)	3	2	1	6
Production	1.66	1.66	1.66	5
Export	Max (\sum Production - \sum Consumption, 0) = Max(0,0)			0 (no export)
Self-consumption	Min (\sum Production, \sum Consumption) = Min(5,6)			5
Import	\sum Consumption - \sum Self consumption			1

The following Smart Energy Manager status data are displayed:

Site Limit	8.4 kW
Site Production	5.0 kW
Site Export	0.0 kW
Self-consume	5.0 kW

Scenario D

PV potential is greater than the loads, which are not balanced across the three phases.

The loads are powered from the PV only, and the excess PV power is fed into grid. In

addition, PV production is limited to maintain the export limit.

	Phase 1 [kW]	Phase 2 [kW]	Phase 3 [kW]	Total [kW]
Potential PV Production	3.33	3.33	3.33	10
Consumption (load)	1	0	0	1
Production	3.13	3.13	3.13	9.4
Export	Max (\sum Production - \sum Consumption, 0) = Max (8.4,0)			8.4
Self-consumption	Min (\sum Production, \sum Consumption) = Min (9.4,1)			1
Import	\sum Consumption - \sum Self consumption			0

The following Smart Energy Manager status data are displayed:

Site Limit	8.4 kW
Site Production	9.4 kW
Site Export	8.4 kW
Self-consume	1.0 kW

Example 3 - Three Phase, Zero Export Limit, Per Phase Limit Mode

In this example, the system has 12kW DC power connected to a three-phase inverter with a maximum AC power of 10kW.

The system export power limit is set to 0W – no power is fed into the grid, and the Per Phase Limit Mode is used.



NOTE

Systems in Australia complying with zero export regulations would be configured with a Site Limit of 0 and using the **Total** option.

► To configure export limitation settings:



NOTE

For detailed guidelines on configuring export limitations settings, refer to the chapter, *Export Limitation Configuration* on page 16).

1. Set the Site Limit to 0.0
2. Set the Limit Mode to "Per Phase".

Scenario A

PV potential is lower than the loads, which are distributed evenly across the 3 phases.

The loads are powered from the PV and from the grid.

PV production is not limited, because there is no export power.

	Phase 1 [kW]	Phase 2 [kW]	Phase 3 [kW]	Total [kW]
Potential PV Production	3.33	3.33	3.33	10
Consumption (load)	4	4	4	12
Production	3.33	3.33	3.33	10
Export	0	0	0	0
	$\Sigma [\text{Max}(\text{Production} - \text{Consumption}, 0)] = \Sigma [\text{Max}(-0.66, 0) (-0.66, 0) (-0.66, 0)]$			
Self-consumption	3.33	3.33	3.33	10
	$\Sigma [\text{Min}(\text{Production}, \text{Consumption})] = \Sigma [\text{Min}(3.33, 4) (3.33, 4) (3.33, 4)]$			
Import	$\Sigma \text{Max}(\text{Consumption} - \text{Self consumption} - \text{Export}, 0)$			2

The following Smart Energy Manager status data are displayed:

Site Limit	0.0 kW
Site Production	10.0 kW
Site Export	0.0 kW
Self-consume	10.0 kW

Scenario B

PV potential is greater than the loads, which are not balanced across the 3 phases.

To maintain a 0W export limit for each phase individually, the production on phase 3 must be limited. Since the three phase inverter is always phase-balanced, the production on phases 1 and 2 is limited accordingly.

	Phase 1 [kW]	Phase 2 [kW]	Phase 3 [kW]	Total [kW]
Potential PV Production	3.33	3.33	3.33	10
Consumption (load)	4	3	1	8
Production	1	1	1	3
Export	0	0	0	0
	$\Sigma [\text{Max}(\text{Production} - \text{Consumption}, 0)] = \Sigma [\text{Max}(-3,0) (-2,0) (0,0)]$			
Self-consumption	1	1	1	3
	$\Sigma [\text{Min}(\text{Production}, \text{Consumption})] = \Sigma [\text{Min}(1,4) (1,3) (1,1)]$			
Import	$\Sigma \text{Max}(\text{Consumption} - \text{Self consumption} - \text{Export}, 0)$			5

The following Smart Energy Manager status data are displayed:

Site Limit	0.0 kW
Site Production	3.0 kW
Site Export	0.0 kW
Self-consume	3.0 kW

Example 4 - Three Phase, 3kW Export Limit, Per Phase Limit Mode

In this example, the system has 12kW DC power connected to a three-phase inverter with a maximum AC power of 10kW.

The system export power limit is set to 3kW, and the Per Phase Limit Mode is used. This means that exporting power on each phase is limited to 1kW.



NOTE

Systems in Netherlands connected to an AC panel with 3x80A main fuses would be configured using the Per Phase option, with a 55kW Site Limit.

- ▶ To configure export limitation settings:



NOTE

For detailed guidelines on configuring export limitations settings, refer to the chapter, *Export Limitation Configuration* on page 16).

1. Set the Site Limit to 3.0
2. Set the Limit Mode to "Per Phase".

Scenario A

PV potential is lower than the loads, which are distributed evenly across the 3 phases. The loads are powered from the PV and from the grid.

PV production is not limited, because there is no export power.

	Phase 1 [kW]	Phase 2 [kW]	Phase 3 [kW]	Total [kW]
Potential PV Production	3.33	3.33	3.33	10
Consumption (load) Production	4	4	4	12
	3.33	3.33	3.33	10
Export	0	0	0	0
	$\Sigma [\text{Max} (\text{Production} - \text{Consumption}, 0)] = \Sigma [\text{Max} (-0.66, 0) (-0.66, 0) (-0.66, 0)]$			0
Self-consumption	3.33	3.33	3.33	10
	$\Sigma [\text{Min} (\text{Production}, \text{Consumption})] = \Sigma [\text{Min} (3.3, 4) (3.3, 4) (3.3, 4)]$			10
Import	$\Sigma \text{Max}(\text{Consumption} - \text{Self consumption} - \text{Export}, 0)$			2

The following Smart Energy Manager status data are displayed:

Site Limit	3.0 kW
Site Production	10.0 kW
Site Export	0.0 kW
Self-consume	10.0 kW

Scenario B

PV potential is greater than the loads, which are not balanced across the 3 phases.

To maintain a 1kW export limit for each phase individually, the production on phase 3 must be limited. Since the three phase inverter is always phase-balanced, the production on phases 1 and 2 is limited accordingly.

	Phase 1 [kW]	Phase 2 [kW]	Phase 3 [kW]	Total [kW]
Potential PV Production	3.33	3.33	3.33	10
Consumption (load)	4	3	1	8
Production	2	2	2	6
Export	0	0	1	1
	$\Sigma [\text{Max}(\text{Production} - \text{Consumption}, 0)] = \Sigma [\text{Max}(-2,0) (-1,0) (1,0)]$			
Self-consumption	2	2	1	5
	$\Sigma [\text{Min}(\text{Production}, \text{Consumption})] = \Sigma [\text{Min}(2,4) (2,3) (2,1)]$			
Import	$\Sigma \text{Max}(\text{Consumption} - \text{Self consumption} - \text{Export}, 0)$			2

The following Smart Energy Manager status data are displayed:

Site Limit	3.0 kW
Site Production	6.0 kW
Site Export	1.0 kW
Self-consume	5.0 kW

Scenario C

PV potential is greater than the loads, which are not balanced across the 3 phases.

To maintain a 1kW export limit for each phase individually, the production on phase 3 must be limited. Since the three phase inverter is always phase-balanced, the production on phases 1 and 2 is limited accordingly.

In this scenario, despite the system production being limited as in the previous scenario, the limitation is less severe because the loads are more balanced, and this allows increased self-consumption.

	Phase 1 [kW]	Phase 2 [kW]	Phase 3 [kW]	Total [kW]
Potential PV Production	3.33	3.33	3.33	10
Consumption (load)	3	2	2	7
Production	3	3	3	9
Export	0	1	1	2
	$\Sigma [\text{Max}(\text{Production} - \text{Consumption}, 0)] = \Sigma [\text{Max}(0,0) (1, 0) (1, 0)]$			
Self-consumption	3	2	2	7
	$\Sigma [\text{Min}(\text{Production}, \text{Consumption})] = \Sigma [\text{Min}(3,3) (3,2) (3,2)]$			
Import	$\Sigma \text{Max}(\text{Consumption} - \text{Self consumption} - \text{Export}, 0)$			0

The following Smart Energy Manager status data are displayed:

Site Limit	3.0 kW
Site Production	9.0 kW
Site Export	2.0 kW
Self-consume	7.0 kW

Appendix D: Minimum Import

Some utilities may require a minimum amount of power to be purchased from the grid before the PV system can start production and supply the loads. *This is equivalent to negative export to the grid.*

Configuring minimum import using SetApp

**NOTE**

The minimum import function for SetApp inverters requires CPU version 4.50xx or above.

► **To configure minimum import using SetApp:**

1. Enter 0.0 in the **Set Site Limit** screen (refer to the chapter, *Export Limitation Configuration* on page 16).
2. Select **Power Control** → **Energy Manager** → **Limit Control** → **Control Mode** → **Min Import Ctrl**



3. Enter the minimum amount of power to be purchased in the **Min Import Ctrl** screen.

Configuring minimum import using the device display



NOTE

The minimum import function for inverters with a display requires CPU version 3.18xx or above.

► **To configure minimum import using the device display:**

1. Enter 0.0 in the **Set Site Limit** screen (refer to the chapter, *Export Limitation Configuration* on page 16).
2. Select **Power Control** → **Energy Manager** → **Limit Control** → **Control Mode** → **Min Import Ctrl**

```
Disable
Export Ctrl.
Production Ctrl.
Min Import Ctrl.
```

3. Enter the minimum amount of power to be purchased in the **Min Import Ctrl** screen.

Appendix E: Regional Considerations

Hawaii

When using the SolarEdge EV Charging Single Phase Inverter, the Excess Solar mode (non-scheduled, solar-only charging) functionality is subject to variations when the inverter is set to one of the Hawaii country settings.

Excess Solar mode operation is available *only* to homeowners with Smart Export tariffs. It will not be available for those with Zero Export tariffs.

During the day, homeowners with either tariff program (Smart Export or Zero Export) will be able to maximize their charging using available solar power combined with grid power priced at Hawaii's lowest retail rates.

To offset the nighttime consumption of electricity priced at Hawaii's high retail rate, it is recommended to set a daytime daily schedule (usually from 10AM to 5PM), and use the Full Power (combined solar and grid charging) mode to charge during non-scheduled periods.

solaredge